

MSP[®] TECHNOLOGY IS SIMPLY THE MOST EFFICIENT HUMIDITY CONTROL SOLUTION FOR PRESERVATION APPLICATIONS



Museums, Libraries and Archives require a stable environment to protect valuable assets. Temperature and humidity levels are critical for preserving valuable paintings, documents, books and negative film. Archival document storage may have different requirements depending on the item being stored. Dehumidification keeps the relative humidity level low and stable, therefore retarding or preventing decay from organic mold formation.

MSP[®] dehumidifiers, using Multiple Small Plate (MSP[®]) technology, is the most energy efficient dehumidification system available, using up to 50% less energy than competitive systems. In addition they are highly reliable with very low maintenance.

▶ Key Benefits & Features

- **Reliable** Simple Technology, No Moving Parts, Low Maintenance
- **Performs** Delivers consistent low dew-point temperatures
- **Sanitary** Full Draining, No Standing Water
- **Efficient** Cuts dehumidification operating costs by up to 50%
- **Fast ROI** Lower capital costs, Competitively priced
- **Versatile** Chilled Water and Refrigerant units
- **Advanced** Single unit provides dehumidification, sensible cooling, heating and ventilation air

DEHUMIDIFIER WITH
MSP[®]TECHNOLOGY

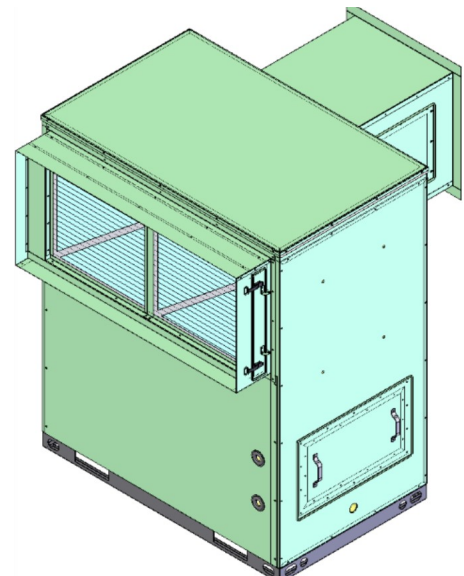

ABOUT MSP® DEHUMIDIFICATION TECHNOLOGY

MSP® Dehumidification Technology is offered in a wide range of super-efficient, industrial grade dehumidification equipment under the MSP Technology brand, and others. Designed specifically for green applications, MSP products are engineered for high performance, guaranteed.

SOME APPLICATIONS FOR MSP TECHNOLOGY

CONDENSATION CONTROL

Supermarkets • Indoor Ice Rinks • Water Treatment
Wastewater Treatment Facilities

INDUSTRIAL DRYING

Leather • Food Drying • Paper Production
Investment Casting • Lumber

PRESERVATION

Dry Storage Warehouses • Paper Storage
Museums • Archives • Libraries • Film Storage

EXPLOSIVE & FLAMMABLE ENVIRONMENTS

Paint Spray Booths • Military • Munitions Storage

CRITICAL ENVIRONMENT

Semiconductor Manufacturing • Pharmaceuticals
Health Care • Laboratories • Clean Rooms

INDOOR FARMING

Produce • Medical Marijuana

ATMOSPHERIC WATER GENERATION

OUR CLIENTS INCLUDE



and many more...

HOW IT WORKS

MSP® DEHUMIDIFICATION AND ATMOSPHERIC WATER GENERATION TECHNOLOGY

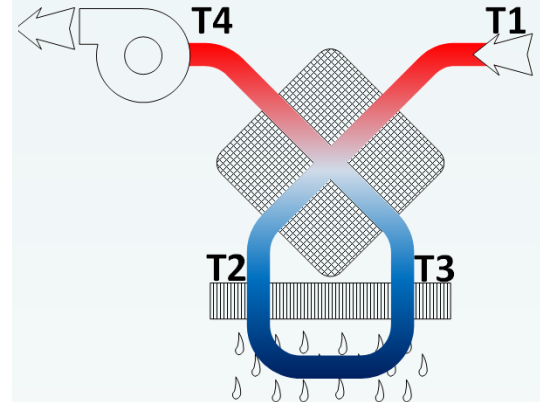

STEP 1 Warm, humid incoming air (T1) flows through the first pass of the plate type air-to-air heat exchangers for pre-cooling and initial condensing and water production. This is accomplished by regenerative thermal exchange with the cooler air that is leaving the heat exchanger. (see step 3)

Advantage: Pre-cooling, condensing and water production by regenerative thermal exchange are "free" and involve no additional equipment.

STEP 2 Pre-cooled air (T2) then passes twice over conventional cooling coils for final cooling, condensing and water production

Advantage: Pre-conditioned air can be treated much more efficiently, using smaller compressors that require as little as one-half the power.

STEP 3 The cool, now dry air (T3) is then drawn back through the opposite side of the heat exchanger where it absorbs some heat from incoming air (see step 1) and continues on to possibly serve a secondary purpose.

Advantage: No heating coil—and no energy penalty—needed to reheat the dehumidified air before it enters the conditioned environment.